

SAFE-T-DRIFT

Top View

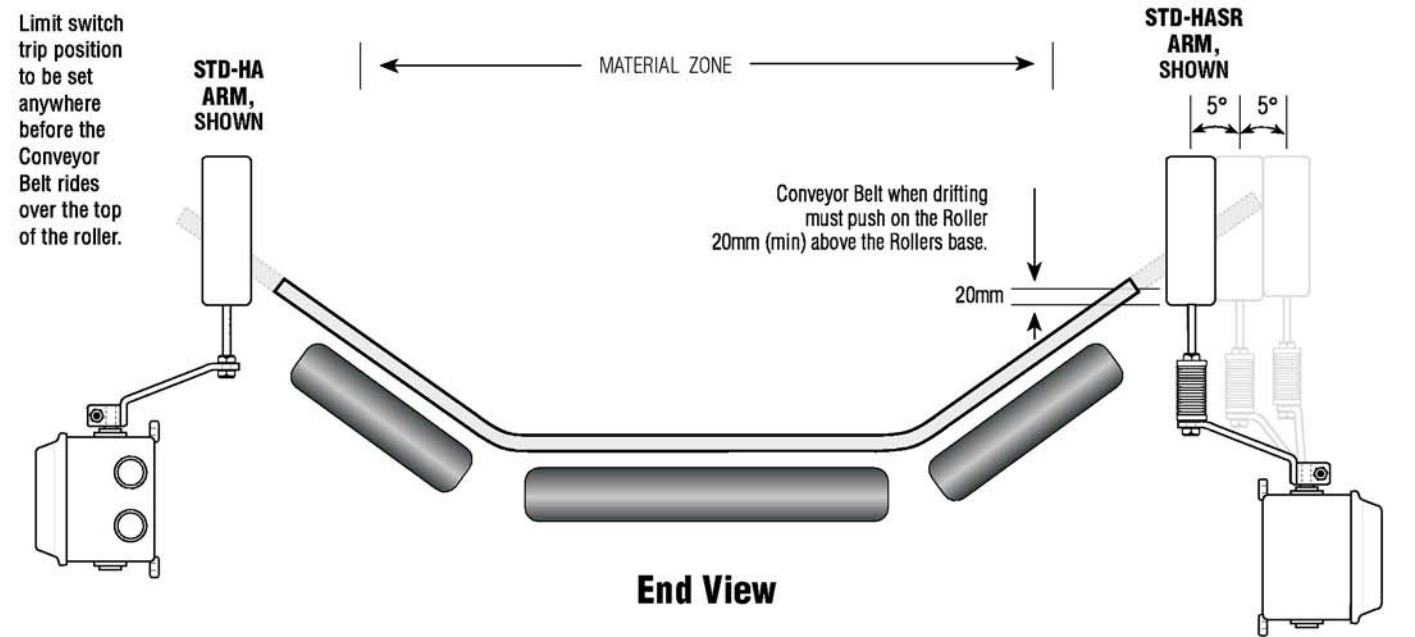
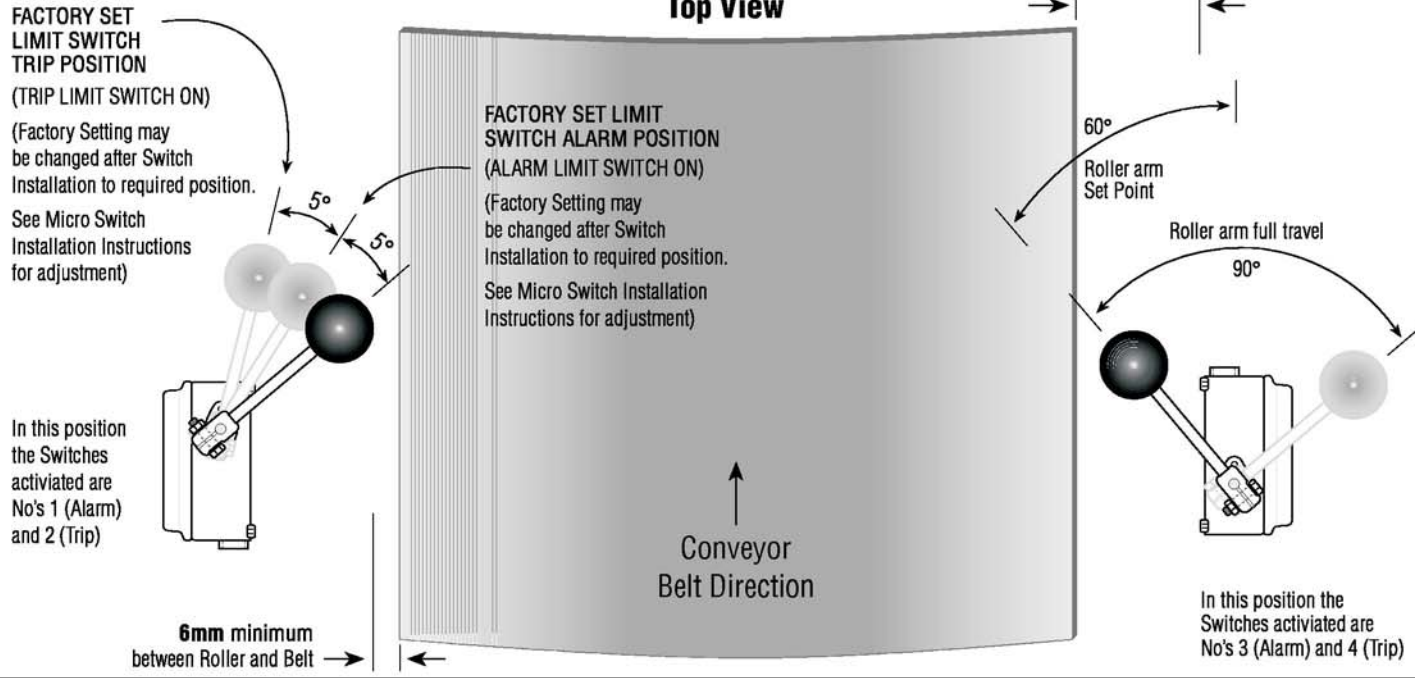

HORIZONTAL ARM

Part No's: STD-HA; STD-HASR;

Installation Instructions

HA Rollers are used for large items on conveyor

Recommended Belt Drifts to use with STD - HA / HASR

Part No's: STD - P - D / - ? STD - P - D - K / - ?

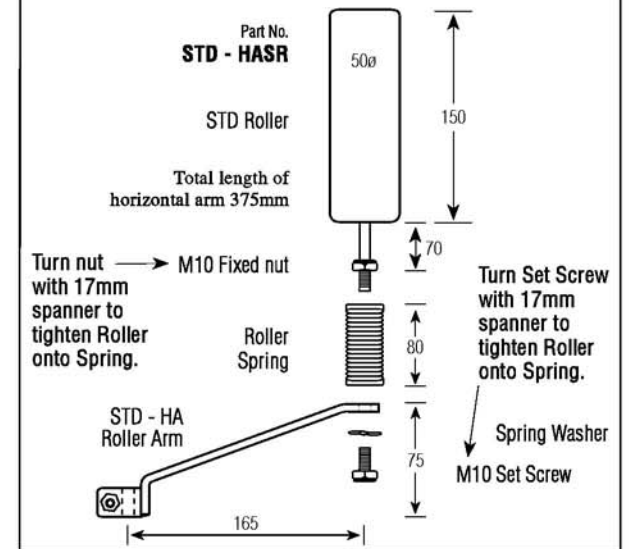
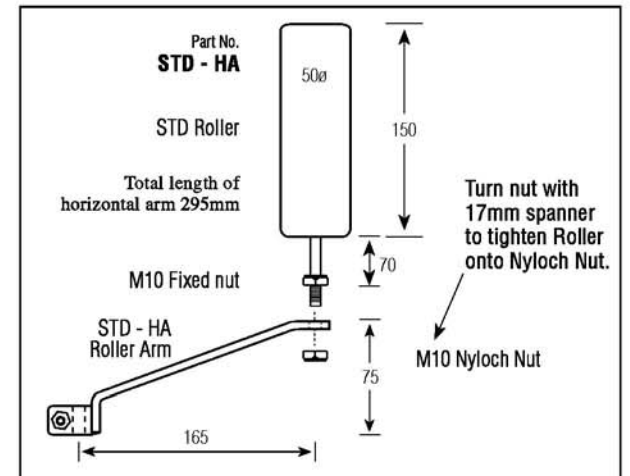

P. O. Box 488
Carletonville
2500
www.armaco.co.za
VAT No. 4720116112



Tel(018)786 3116
Int(+27)18 786 3116
Fax(018)786 3892
Int(+27)18 786 3892
elismc@armaco.co.za

Reg No.: CK880457723